



SERVICE PARTS LIST

BULLETIN NO.
54-06-2375

SPECIFY CATALOG NO. AND SERIAL NO. WHEN ORDERING PARTS			REVISED BULLETIN	DATE
CORDLESS M12™ 360° Lantern				June 2014
CATALOG NO.	2362-20	STARTING SERIAL NO.	WIRING INSTRUCTION	
		G26A		

EXAMPLE:

00	0
----	---

 Component Parts (Small #) Are Included
 When Ordering The Assembly (Large #).

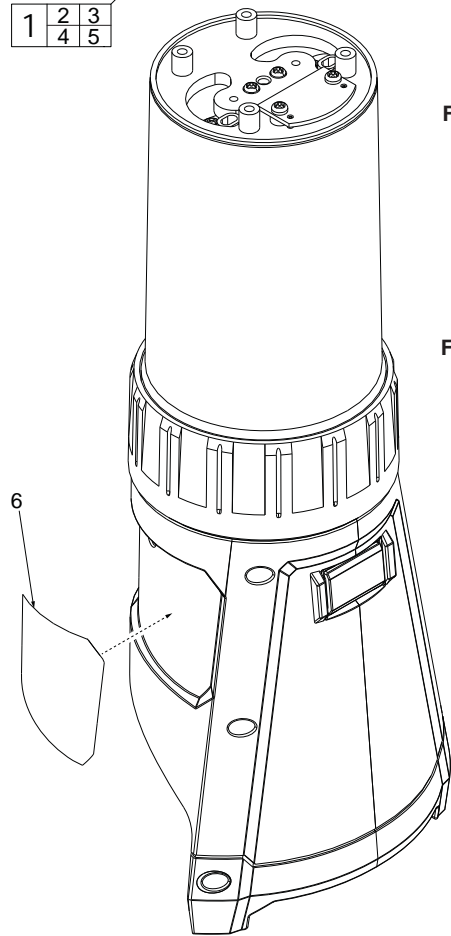
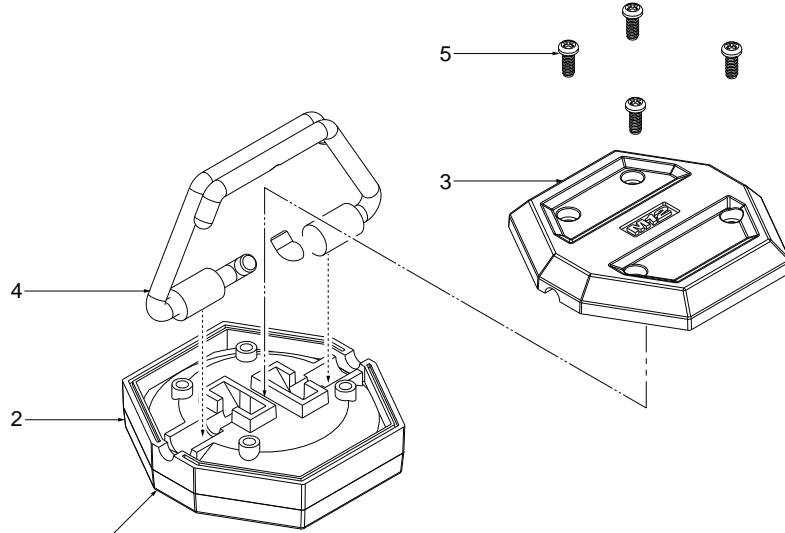

1	2	3
4	5	

FIG.	PART NO.	DESCRIPTION OF PART	NO. REQ.
1	14-36-2362	Cap / Hook Assembly	(1)
2	-----	Cap	(1)
3	-----	Cover	(1)
4	-----	Hook Assembly	(2)
5	-----	M4 x 12mm Pan Hd. T-10 Screw	(4)
6	12-20-2365	Service Nameplate	(1)

- FIG. NOTES**
- 5 Care must be used when securing fasteners in tool. To prevent stripping do not over tighten. It is not recommended to use power tools, hand tighten only. Torque screws #4 to 5-7 in/lbs (6-8 kg/cm). Torque screws #10 to 3-4 in/lbs (3.5-4.5 kg/cm).
 - 6 A clean, dry surface is essential for proper performance for any adhesive system. The area intended for application of any adhesive label or nameplate must be prepared by cleaning with isopropyl alcohol. The solvent is to be applied with a clean, lint free applicator and the surface allowed to dry before applying the label or nameplate.