



# SERVICE PARTS LIST

**BULLETIN NO.**  
**54-07-3500**

SPECIFY CATALOG NO. AND SERIAL NO. WHEN ORDERING PARTS		REVISED BULLETIN	DATE
<b>ALKALINE GREEN CROSS LINE LASER</b>			Mar. 2022
CATALOG NO. <b>3421</b>	STARTING SERIAL NO. <b>M70A</b>	WIRING INSTRUCTION	

Service needs pertaining to accuracy or calibration can only be performed at Milwaukee Authorized Repair Centers:  
**MILWAUKEE ELECTRIC TOOL central repair 1401 Sycamore Ave. Greenwood, MS 38930-7277**  
 OR  
 Via e-Service at: [www.milwaukeetool.com/e-service](http://www.milwaukeetool.com/e-service). Questions, please call 1.800.SAWDUST  
 OR  
 Return it to a **MILWAUKEE FACTORY SERVICE CENTER** location, freight prepaid and insured.  
 A copy of the proof of purchase should be included with the return product."

**EXAMPLE:**  
 Component Parts (Small #)  
 Are Included When Ordering  
 The Assembly (Large #).

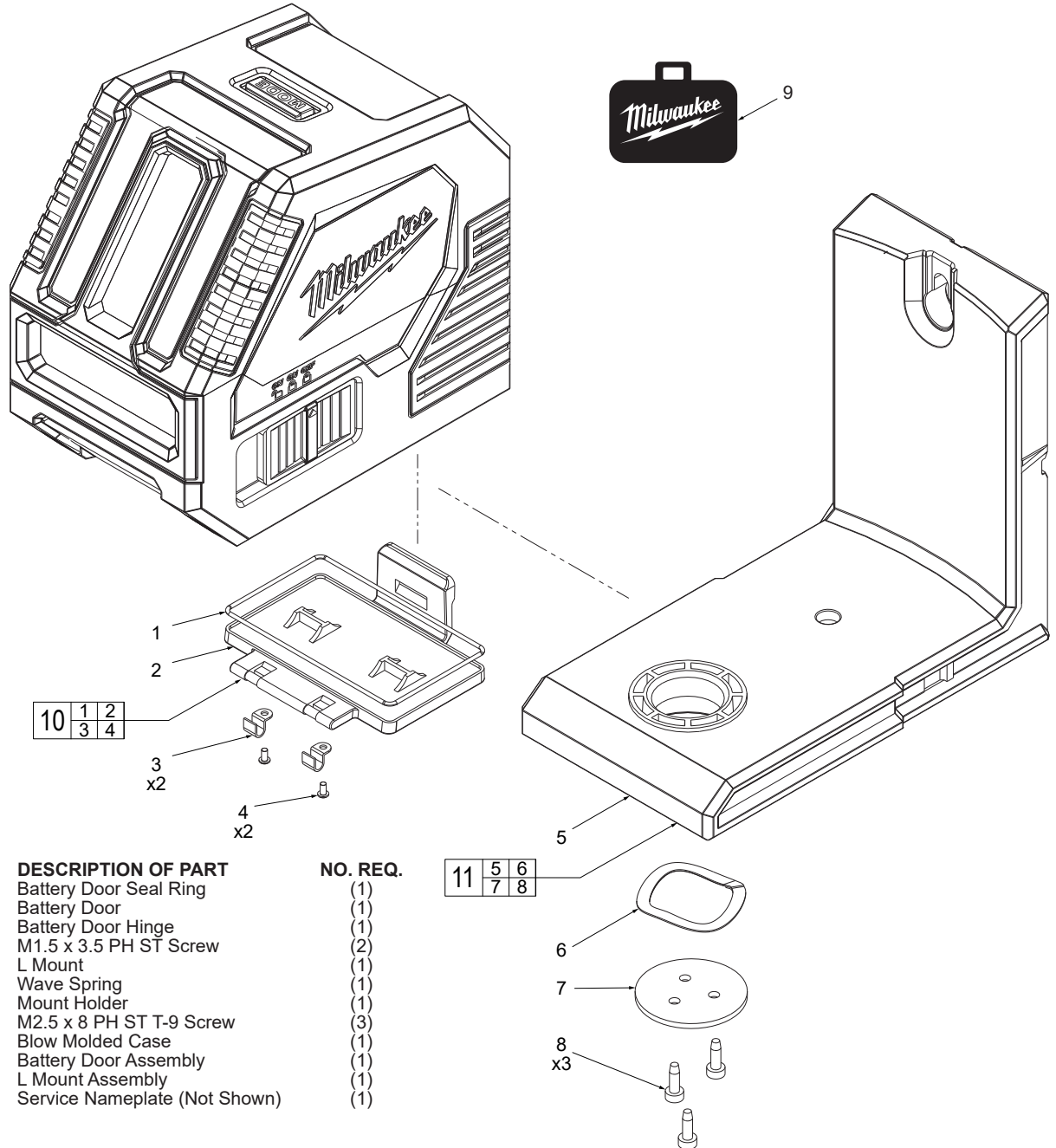

FIG.	PART NO.	DESCRIPTION OF PART	NO. REQ.
1	-----	Battery Door Seal Ring	(1)
2	-----	Battery Door	(1)
3	-----	Battery Door Hinge	(1)
4	-----	M1.5 x 3.5 PH ST Screw	(2)
5	-----	L Mount	(1)
6	-----	Wave Spring	(1)
7	-----	Mount Holder	(1)
8	-----	M2.5 x 8 PH ST T-9 Screw	(3)
9	42-55-0107	Blow Molded Case	(1)
10	43-62-0067	Battery Door Assembly	(1)
11	31-10-0023	L Mount Assembly	(1)
12	12-20-3421	Service Nameplate (Not Shown)	(1)

**FIG. 12 NOTES**  
 A clean, dry surface is essential for proper performance for any adhesive system. The area intended for application of any adhesive label or nameplate must be prepared by cleaning with isopropyl alcohol. The solvent is to be applied with a clean, lint free applicator and the surface allowed to dry before applying the label or nameplate.